

CATALOGUE FOR SHIPPING

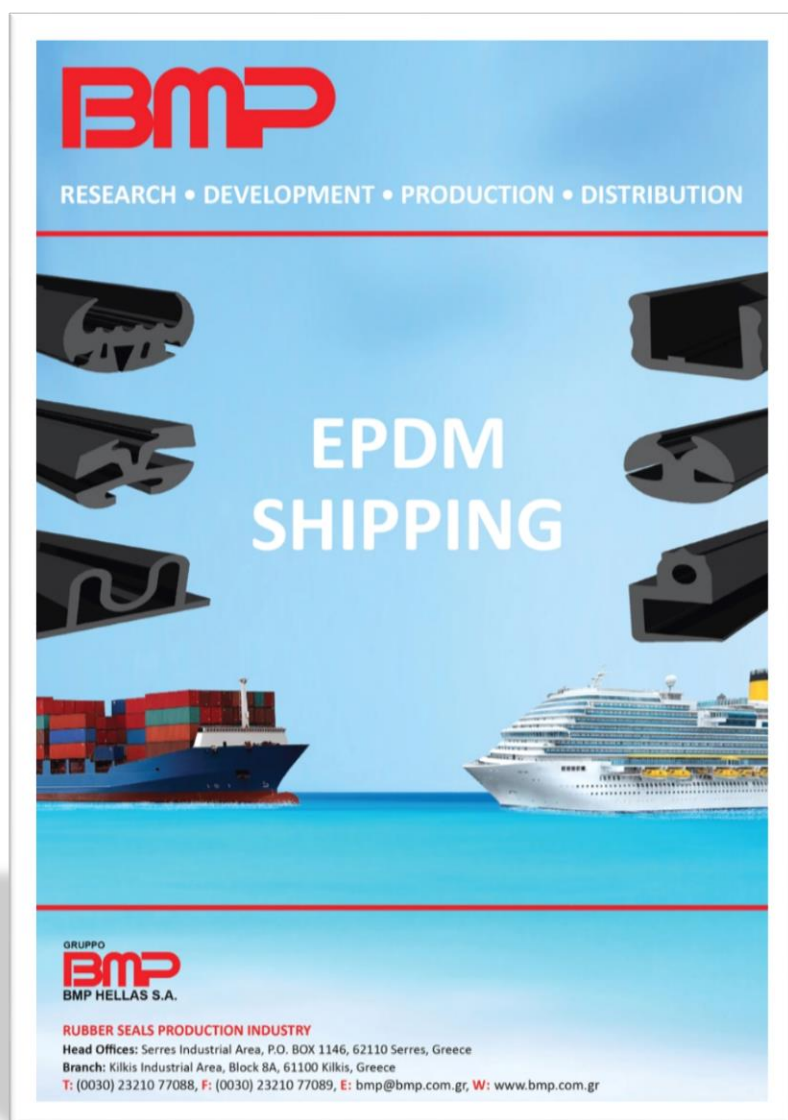

BMP

RESEARCH • DEVELOPMENT • PRODUCTION • DISTRIBUTION



**EPDM
SHIPPING**





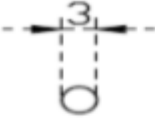
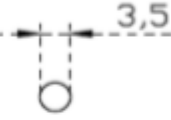
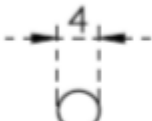
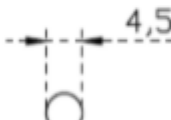
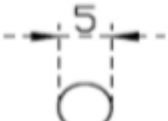
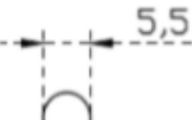

GRUPPO
BMP
BMP HELLAS S.A.

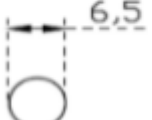
RUBBER SEALS PRODUCTION INDUSTRY
Head Offices: Serres Industrial Area, P.O. BOX 1146, 62110 Serres, Greece
Branch: Kilkis Industrial Area, Block 8A, 61100 Kilkis, Greece
T: (0030) 23210 77088, F: (0030) 23210 77089, E: bmp@bmp.com.gr, W: www.bmp.com.gr



No	Size	Catalogue Code	Material	Hardness	Unit
1	5*10	01-5514-40	sponge	15+2	mt
2	5*15	01-5524-40	sponge	15+2	mt
3	5*20	01-5534-40	sponge	15+2	mt
4	5*25	01-5544-40	sponge	15+2	mt
5	5*30	01-5554-40	sponge	15+2	mt
6	5*35	01-5564-40	sponge	15+2	mt
7	5*40	01-5574-40	sponge	15+2	mt
8	5*50	01-5594-40	sponge	15+2	mt
9	5*100	01-5694-40	sponge	15+2	mt
10	10*10	02-2014-40	sponge	15+2	mt
11	10*15	02-2024-40	sponge	15+2	mt
12	10*20	02-2034-40	sponge	15+2	mt
13	10*30	02-2054-40	sponge	15+2	mt
14	10*40	02-2074-40	sponge	15+2	mt
15	10*50	02-2094-40	sponge	15+2	mt
16	15*15	02-7024-40	sponge	15+2	mt
17	15*20	02-7034-40	sponge	15+2	mt
18	15*25	02-7044-40	sponge	15+2	mt
19	15*30	02-7054-40	sponge	15+2	mt
20	15*35	02-7064-40	sponge	15+2	mt
21	15*40	02-7074-40	sponge	15+2	mt
22	15*50	02-7094-40	sponge	15+2	mt
23	20*20	03-3534-40	sponge	15+2	mt
24	20*25	03-3544-40	sponge	15+2	mt
25	20*30	03-3554-40	sponge	15+2	mt
26	20*35	03-3564-40	sponge	15+2	mt
27	20*40	03-3574-40	sponge	15+2	mt



NO	Picture	Catalogue Code	Material	Hardness	Unit
1		1001-99-38	epdm	65+5	mt
2		1002-99-38	epdm	65+5	mt
3		1003-99-38	epdm	65+5	mt
4		1004-99-38	epdm	65+5	mt
5		1005-99-38	epdm	65+5	mt
6		1006-99-38	epdm	65+5	mt
7		1007-99-38	epdm	65+5	mt
8		1008-99-38	epdm	65+5	mt



9		1009-99-38	epdm	65+5	mt
10		1010-99-38	epdm	65+5	mt
11		1011-99-38	epdm	65+5	mt
12		1012-99-38	epdm	65+5	mt
13		1009-99-38	epdm	65+5	mt
14		1014-99-38	epdm	65+5	mt
15		1015-99-38	epdm	65+5	mt

GRUPPO

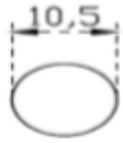
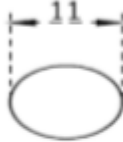
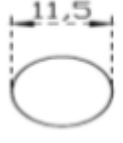
BMP

BMP HELLAS S.A.

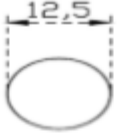
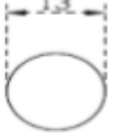
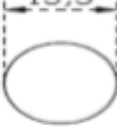
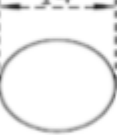
16		1016-99-38	epdm	65+-5	mt
17		1017-99-38	epdm	65+-5	mt
18		1018-99-38	epdm	65+-5	mt
19		1019-99-38	epdm	65+-5	mt





20		1020-99-38	epdm	65+5	mt
21		1021-99-38	epdm	65+5	mt
22		1022-99-38	epdm	65+5	mt
23		1023-99-38	epdm	65+5	mt
24		1024-99-38	epdm	65+5	mt
25		1025-99-38	epdm	65+5	mt

GRUPPO

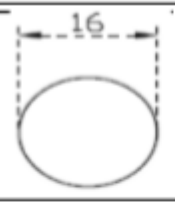
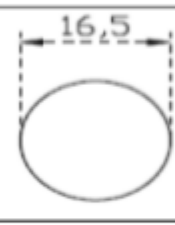
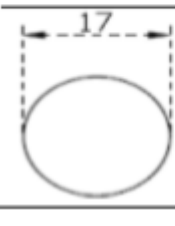
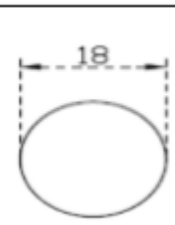
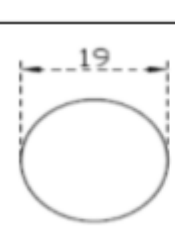
BMP

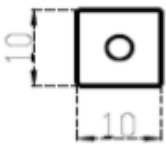
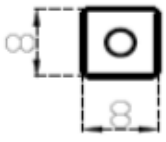
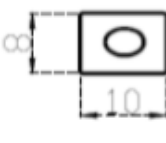

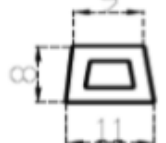
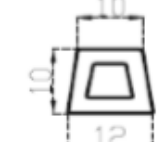
BMP HELLAS S.A.

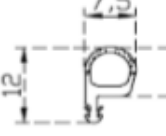
26		1027-99-38	epdm	65+-5	mt
27		1028-99-38	epdm	65+-5	mt
28		1029-99-38	epdm	65+-5	mt
29		1031-99-38	epdm	65+-5	mt
30		1033-99-38	epdm	65+-5	mt

NO	Picture	Catalogue Code	Material	Hardness	Unit
1		1209-99-27	epdm	65+5	mt
2		1210-99-27	epdm	65+5	mt
3		1211-99-27	epdm	65+5	mt
4		1212-99-27	epdm	65+5	mt
5		1213-99-27	epdm	65+5	mt
6		1214-99-27	epdm	65+5	mt
7		1021-99-56	coex	Epdm 65+5 sponge 18+2	mt
8		1026-99-56	coex	Epdm 65+5 sponge 18+2	mt

9		1099-56	coex	Epdm 65+5 sponge 18+2	mt
10		1028-99-56	coex	Epdm 65+5 sponge 18+2	mt
11		1034-99-56	coex	Epdm 65+5 sponge 18+2	mt
12		1076-99-36	sponge	15+2	mt
13		1191-99-36	sponge	18+2	mt

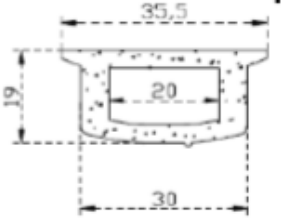
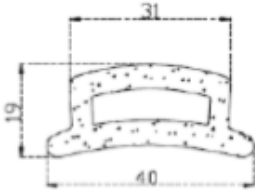
14		1192-99-36	sponge	18+2	mt
15		1194-99-36	sponge	15+2	mt

16		1144-99-36	sponge	18+-2	mt
17		1134-99-36	sponge	18+-2	mt
18		1050-98-18	epdm	65+-5	mt

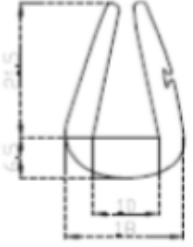
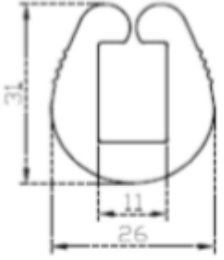
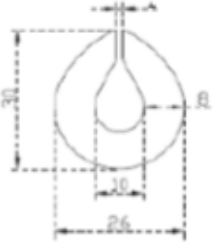
19		1051-98-18	epdm	65+5	mt
20		1131-99-18	pvc	66+3	mt
21		1169-99-18	epdm	65+5	mt

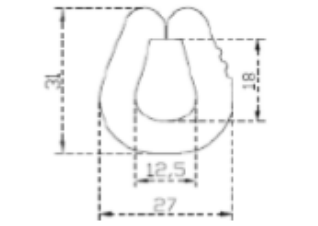
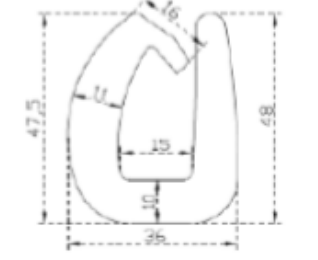
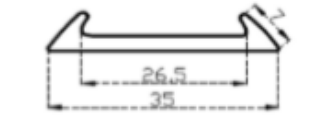
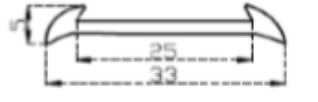
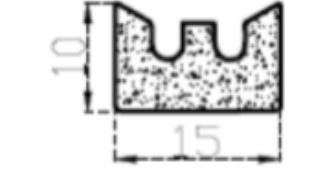
22		1192-99-18	pvc	83+3	mt
23		1196-99-18	pvc	66+3	mt
24		1010-99-22	pvc	83+3	mt
25		1010-99-27	epdm	65+5	mt
26		1058-99-36	sponge+ 13 mm adhesive tape	18+2	mt

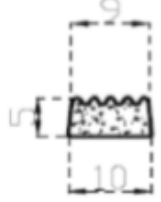
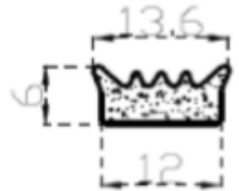
27		1086-99-36	sponge+ 8 mm adhesive tape	18+2	mt
28		1095-99-36	sponge+ 10mm adhesive tape	18+2	mt

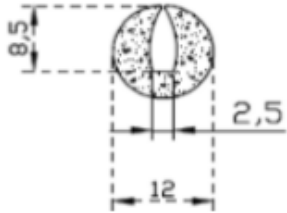
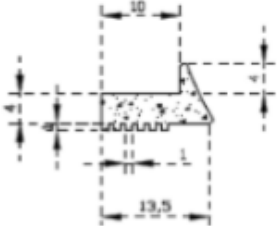
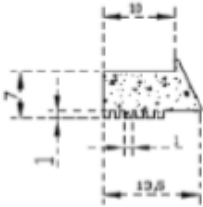
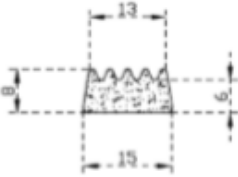
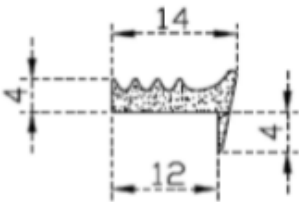
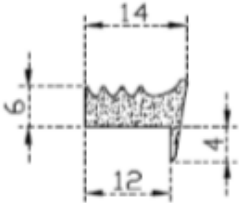
29		1158-99-36	sponge	18+-2	mt
30		1168-99-36	sponge+ 8 mm adhesive tape	18+-2	mt
31		1173-99-36	sponge+ 8 mm adhesive tape	18+-2	mt
32		1200-99-36	sponge+ 13 mm adhesive tape	12+-2	mt
33		1210-99-36	sponge+ 10 mm adhesive tape	18+-2	mt
34		1211-99-36	sponge+ 10 mm adhesive tape	18+-2	mt

